

*Overground hydrant breakable DN 80
PN 10 and ductile iron PN 10/16*

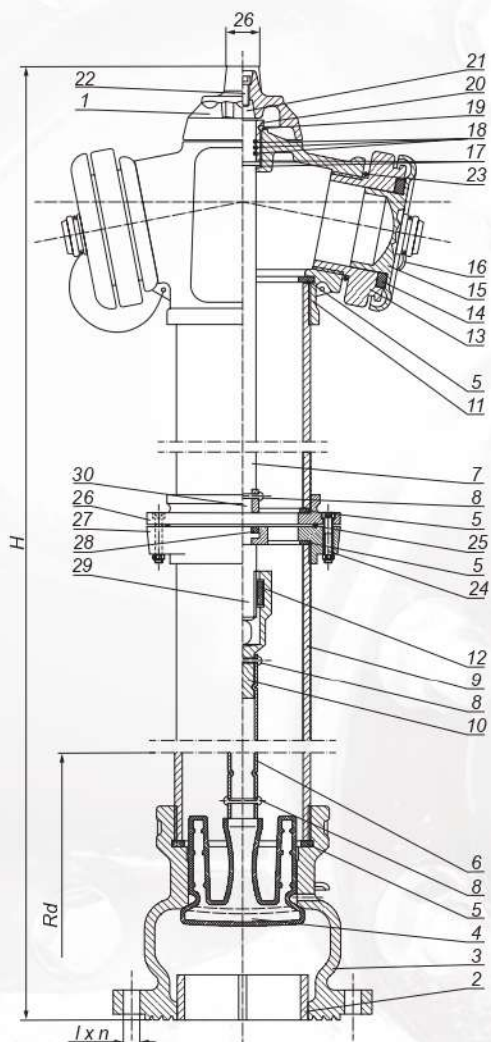

Overground hydrant breakable DN 80 PN 10 and ductile iron PN 10/16

No.	Description	Pcs.	Material
1.	Knob	1	EN-GJL-250/EN-GJS-500-7
2.	Safety ring	1	EN-GJL-250/EN-GJS-500-7
3.	Chamber	1	EN-GJL-250/EN-GJS-500-7
4.	Piston	1	EN-GJS-500-7/EPDM/NBR
5.	Gasket	4	EPDM/NBR
6.	Sliding spindle down	1	Stainless steel A2/1.4301 Steel P235
7.	Sliding spindle up	1	Stainless steel 2H13
8.	Rivet	3	Steel St 2/Steel C1006
9.	Column	1	Stainless steel A2/1.4301 Steel P235 EN-GJS-500-7
10.	Nut casing	1	EN-GJS-500-7
11.	Head	1	EN-GJL-250/EN-GJS-500-7
12.	Nut	1	Brass MO59
13.	Storz coupling	2	Aluminum AK11
14.	Cap gasket	2	EPDM/NBR
15.	Cap	2	EN-GJL-250/EN-GJS-500-7/AK11/ Polyethylene
16.	Cord	1	Steel
17.	Bearing	2	Tamamid
18.	O-ring	3	EPDM/NBR
19.	O-ring	1	EPDM/NBR
20.	Choke	1	Brass MO59
21.	Spindle	1	Stainless steel 2H13
22.	Allen screw	1	Galvanized steel 8.8 class/ Stainless steel A2
23.	Storz coupling gasket	2	EPDM/NBR
24.	Screw, pad, nut	4	Stainless steel A2/A4
25.	O-ring	1	EPDM/NBR
26.	Upper flange	1	EN-GJS-500-7
27.	Lower flange	1	EN-GJS-500-7
28.	Middle spindle nut	1	Brass MO59
29.	Middle spindle	1	Stainless steel 2H13
30.	Clutch	1	EN-GJL-250/EN-GJS-500-7



Overground hydrant breakable with a nominal diameter of 80 mm for pressure 1,0 and 1,6 MPa with an automatic drainage device in the lower chamber.

Intended for drawing water from a general-purpose pipeline with a nominal diameter of 80 mm, water at a temperature up to 70°C and a pressure of 1,0 and 1,6 MPa.

Certificate of Conformity CNBOP 1438/CPR/0478
Coating: poliester paint UV resisted, min. 250 µm
Flange connection: PN-EN 1092-2:1999
Nominal pressure: 1,0/1,6 MPa, PN 10/16

Possibility of exchanging head of the hydrant once broken without the need digging out lower part of the hydrant.

DN	Wielkość	H	Rd	l	n	Weight
80	A	1900	1250	18	8	37,00
	B	2150	1500	18	8	40,00
	C	2450	1800	18	8	44,00
	X	as per order				

*Overground hydrant breakable DN 100
PN 10 and ductile iron PN 10/16*



Overground hydrant breakable DN 100 PN 10 and ductile iron PN 10/16

No.	Description	Pcs.	Material
1.	Knob	1	EN-GJL-250/EN-GJS-500-7
2.	Safety ring	1	EN-GJL-250/EN-GJS-500-7
3.	Chamber	1	EN-GJL-250/EN-GJS-500-7
4.	Piston	1	EN-GJS-500-7/EPDM/NBR
5.	Gasket	3	EPDM/NBR
6.	Sliding spindle down	1	Stainless steel A2/1.4301 Steel P235
7.	Sliding spindle up	1	Stainless steel 2H13
8.	Rivet	2	Steel St 2/Steel C1006
9.	Column	1	Stainless steel A2/1.4301 Steel P235 EN-GJS-500-7
10.	Nut casing	1	EN-GJS-500-7
11.	Head	1	EN-GJL-250/EN-GJS-500-7
12.	Nut	1	Brass MO59
13.	Storz coupling	2	Aluminum AK11
14.	Cover gasket	2	EPDM/NBR
15.	Cover	2	EN-GJL-250/EN-GJS-500-7 AK11/Polyethylene
16.	Cord	1	Steel
17.	Bearing	2	Tarnamid
18.	O-ring	3	EPDM/NBR
19.	O-ring	1	EPDM/NBR
20.	Choke	1	Brass MO59
21.	Spindle	1	Stainless steel 2H13
22.	Allen screw	1	Galvanized steel 8.8 class Stainless steel A2
23.	Storz coupling gasket	2	EPDM/NBR
24.	Storz coupling DN 100	1	Aluminum AK11
25.	Storz coupling cover DN 100	1	EN-GJL-250/EN-GJS-500-7 AK11/Polyethylene
26.	Reducer	1	EN-GJS-500-7
27.	Screw, pad, nut	4	Galvanized steel 8.8 class Stainless steel A2
28.	O-ring	1	EPDM/NBR
29.	Upper flange	1	EN-GJS-500-7
30.	Lower flange	1	EN-GJS-500-7
31.	Middle spindle nut	1	Stainless steel 2H13 Brass MO59
32.	Middle spindle	1	Stainless steel 2H13
33.	Clutch	1	EN-GJL-250/EN-GJS-500-7

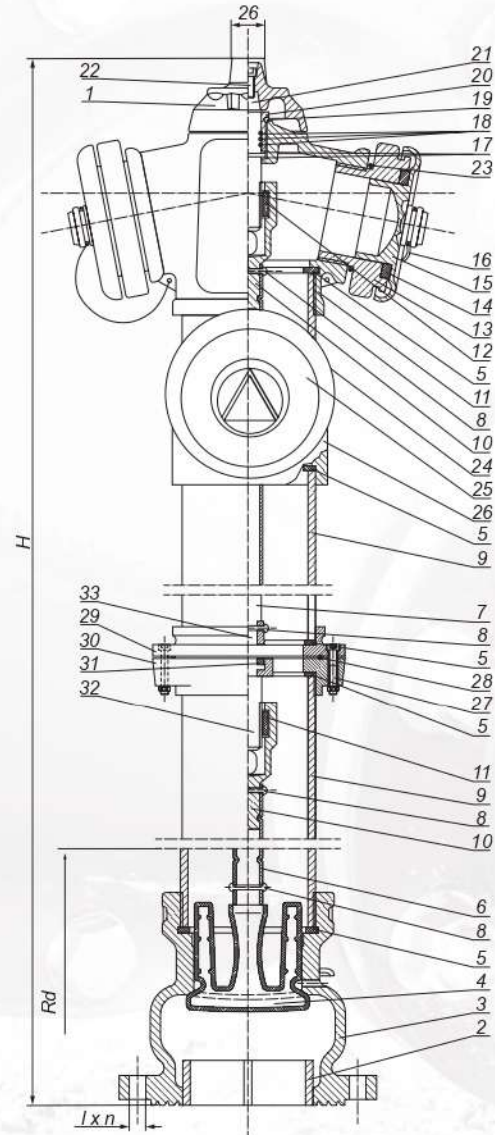

Overground hydrant breakable with a nominal diameter of 100 mm for pressure 1,0 and 1,6 MPa with an automatic drainage device in the lower chamber.

Intended for drawing water from a general-purpose pipeline with a nominal diameter of 100 mm, water at a temperature up to 70°C and a pressure of 1,0 and 1,6 MPa.

Certificate of Conformity CNBOP 1438/CPR/0522

Coating: poliester paint UV resisted, min. 250 µm

Flange connection: PN-EN 1092-2:1999

Nominal pressure: 1,0/1,6 MPa, PN 10/16

Possibility of exchanging head of the hydrant once broken without the need digging out lower part of the hydrant.

DN	Size	H	Rd	l	n	Weight
100	A	1900	1250	18	8	43,00
	B	2150	1500	18	8	46,00
	C	2450	1800	18	8	50,00
	X	as per order				