

Service valve ductile iron PN 10/16



DN20, DN25



DN32, DN40, DN50

Service valve ductile iron PN 10/16

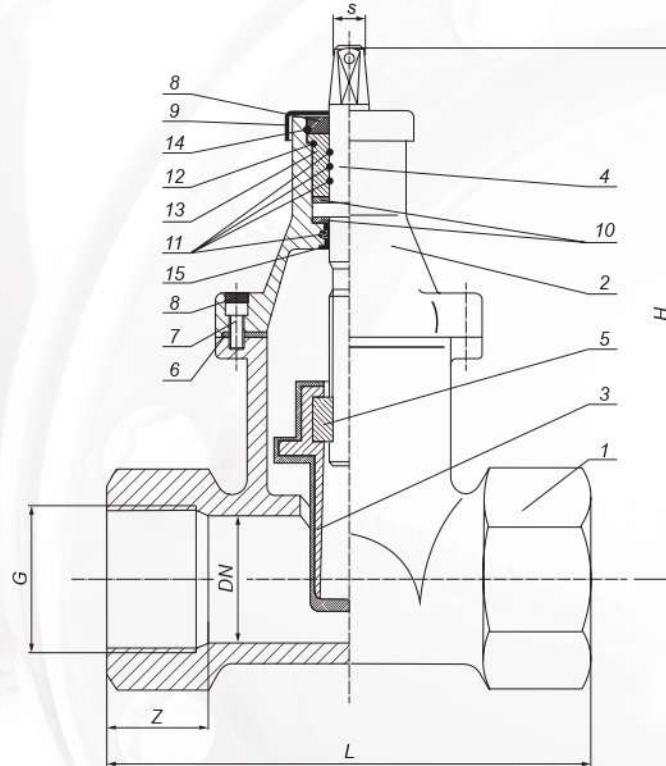

No.	Description	Pcs.	Material
1.	Body	1	EN-GJS-500-7
2.	Cover	1	EN-GJS-500-7
3.	Rubberized wedge	1	EN-GJS-500-7/Brass MO59/ EPDM/NBR
4.	Spindle	1	Stainless steel 2H13
5.	Nut	1	Brass MO59
6.	Cover gasket	1	EPDM/NBR
7.	Allen screw	4	Galvanized steel 8.8 class/ Stainless steel A2
8.	Screw shield	5	Glue/paraffin
9.	Spindle shield	1	EPDM/NBR
10.	Bearing	2	Tarnamid
11.	Spindle O-ring	4	EPDM/NBR
12.	Choke O-ring	1	EPDM/NBR
13.	Choke	1	Brass MO59
14.	Protection ring	1	Special steel
15.	Locking sleeve	1	Tarnamid

It is used to cut off flow of chemically inert liquids of temperature up to 70°C in pipelines and installations.

Coating: poliester paint min. 250 µm
Nominal pressure: 1,0/1,6 MPa; PN 10/16
Requirements and inspection according to PN-EN 1074-1,2:2002
Threaded socket: PN-EN 10226-1:2006

Option to exchange O-rings under pressure on a working pipeline.

DN	G	L	H	s	z	Weight
20*	3/4"	100	120	14	20	1,20
25*	1"	100	120	14	20	1,20
32	5/4"	120	170	14	20	2,80
40	6/4"	120	170	14	20	2,70
50	2"	185	215	14	20	7,20

* cover screwed into the body of the gate valve