

*Overground hydrant DN 80
PN 10 and ductile iron PN 10/16*

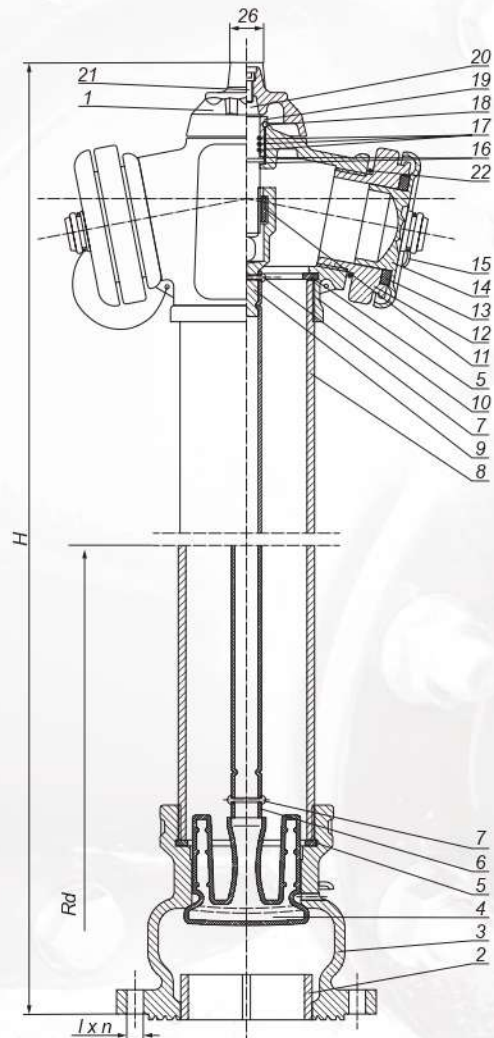

Overground hydrant DN 80 PN 10 and ductile iron PN 10/16

No.	Description	Pcs.	Material
1.	Knob	1	EN-GJL-250/EN-GJS-500-7
2.	Safety ring	1	EN-GJL-250/EN-GJS-500-7
3.	Chamber	1	EN-GJL-250/EN-GJS-500-7
4.	Piston	1	EN-GJS-500-7/EPDM/NBR
5.	Gasket	2	EPDM/NBR
6.	Sliding spindle	1	Stainless steel A2/1.4301 Steel P235
7.	Rivet	2	Steel St 2/Steel C1006
8.	Column	1	Stainless steel A2/1.4301 Steel P235 EN-GJS-500-7
9.	Nut casing	1	EN-GJS-500-7
10.	Head	1	EN-GJL-250/EN-GJS-500-7
11.	Nut	1	Brass MO59
12.	Storz coupling	2	Aluminum AK11
13.	Cover gasket	2	EPDM/NBR
14.	Cover	2	EN-GJL-250/EN-GJS-500-7/ AK11/Polyethylene
15.	Cord	1	Steel
16.	Bearing	2	Tarnamid
17.	O-ring	3	EPDM/NBR
18.	O-ring	1	EPDM/NBR
19.	Choke	1	Brass MO59
20.	Spindle	1	Stainless steel 2H13
21.	Allen screw	1	Galvanized steel 8.8 class/ Stainless steel A2
22.	Gasket	2	EPDM/NBR



Overground hydrant with a nominal diameter of 80 mm for pressure 1,0 and 1,6 MPa with an automatic drainage device in the lower chamber. Intended for drawing water from a general-purpose pipeline with a nominal diameter of 80 mm, water at a temperature up to 70°C and a pressure of 1,0 and 1,6 MPa.

DN	Size	H	Rd	l	n	Weight
80	A	1900	1250	18	8	33,00
	B	2150	1500	18	8	36,00
	C	2450	1800	18	8	40,00
	X	as per order				

Certificate of Conformity CNBOP 1438/CPR/0143
Coating: poliester paint UV resisted, min. 250 µm
Flange connection: PN-EN 1092-2:1999
Nominal pressure: 1,0/1,6 MPa, PN 10/16

*Overground hydrant DN 100
PN 10 and ductile iron PN 10/16*



Overground hydrant DN 100 PN 10 and ductile iron PN 10/16

No.	Description	Pcs.	Material
1.	Knob	1	EN-GJL-250/EN-GJS-500-7
2.	Safety ring	1	EN-GJL-250/EN-GJS-500-7
3.	Chamber	1	EN-GJL-250/EN-GJS-500-7
4.	Piston	1	EN-GJS-500-7/EPDM/NBR
5.	Gasket	3	EPDM/NBR
6.	Sliding spindle	1	Stainless steel A2/1.4301 Steel P235
7.	Rivet	2	Steel St 2/Steel C1006
8.	Column	1	Stainless steel A2/1.4301 Steel P235 EN-GJS-500-7
9.	Nut casing	1	EN-GJS-500-7
10.	Head	1	EN-GJL-250/EN-GJS-500-7
11.	Nut	1	Brass MO59
12.	Cap	2	Aluminium AK11
13.	Cover gasket	2	EPDM/NBR
14.	Cover	2	EN-GJL-250/EN-GJS-500-7 AK11/Polyethylene
15.	Cord	1	Steel
16.	Bearing	2	Tarnamid
17.	O-ring	3	EPDM/NBR
18.	O-ring	1	EPDM/NBR
19.	Choke	1	Brass MO59
20.	Spindle	1	Stainless steel 2H13
21.	Allen screw	1	Galvanized steel 8.8 class/ Stainless steel A2
22.	Cap gasket	2	EPDM/NBR
23.	Cap DN 100	1	Aluminium AK11
24.	Cap cover DN 100	1	EN-GJL-250/EN-GJS-500-7 AK11/Polyethylene
25.	Reducer	1	EN-GJS-500-7

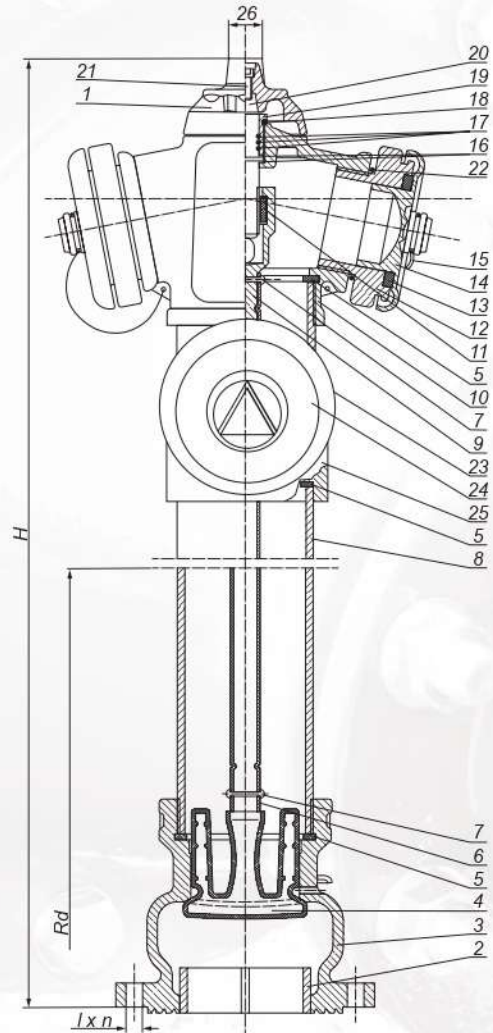

Overground hydrant with a nominal diameter of 100 mm for pressure 1,0 and 1,6 MPa with an automatic drainage device in the lower chamber. Intended for drawing water from a general-purpose pipeline with a nominal diameter of 100 mm, water at a temperature up to 70°C and a pressure of 1,0 and 1,6 MPa.

Certificate of conformity CNBOP 1438/CPR/0521
Coating: poliester paint UV resisted, min. 250 µm
Flange connection: PN-EN 1092-2:1999
Nominal pressure: 1,0/1,6 MPa, PN 10/16

DN	Size	H	Rd	l	n	Weight
100	A	1900	1250	18	8	39,00
	B	2150	1500	18	8	42,00
	C	2450	1800	18	8	46,00
	X	as per order				